

ICC-ES Evaluation Report

ESR-1223

Reissued October 2023

This report also contains:

FBC Supplement

Subject to renewal October 2024

ICC-ES Evaluation Reports are not to be construed as representing aesthetics or any other attributes not specifically addressed, nor are they to be construed as an endorsement of the subject of the report or a recommendation for its use. There is no warranty by ICC Evaluation Service, LLC, express or implied, as to any finding or other matter in this report, or as to any product covered by the report.

Copyright © 2023 ICC Evaluation Service, LLC. All rights reserved.

<p>DIVISION: 03 00 00 - CONCRETE</p> <p>Section: 03 11 00 – Concrete Forming</p>	<p>REPORT HOLDER:</p> <p>NUFORM BUILDING TECHNOLOGIES INC.</p>	<p>EVALUATION SUBJECT:</p> <p>CONFORM ®</p>	
--	--	---	---

1.0 EVALUATION SCOPE

Compliance with the following codes:

- 2015 [International Building Code® \(IBC\)](#)
- 2015 [International Residential Code® \(IRC\)](#)
- Other Codes (see Section 8.0)

Property evaluated:

- Structural (for concrete wall assemblies)
- Weather resistance
- Surface-burning characteristics
- Fire resistance
- Fire separation
- Dampproofing

1.1 Evaluation to the following green code(s) and/or standards:

- 2022 [California Green Building Standards Code \(CALGreen\)](#), Title 24, Part 11

Attributes verified:

See Section 3.1

2.0 USES

Conform components are used as stay-in-place formwork for plain and reinforced concrete load-bearing and non-load-bearing walls. Walls formed with CF6, CF8 and CF8i components are also used as foundation walls.

3.0 DESCRIPTION

3.1 General:

Conform is a permanent formwork system for concrete walls and consists of hollow, rigid polymer, flat profile, interlocking components that are filled with either reinforced or plain structural concrete. Conform formwork serves as the exterior and interior wall finish for the concrete walls.

The attribute of the Conform formwork system has been verified as conforming to the provision of CALGreen Sections A4.404.3.3 for premanufactured building systems. Note that decisions on compliance for those areas rest with the user of this report. The user is advised of the project-specific provisions that may be contingent

upon meeting specific conditions, and the verification of those conditions is outside the scope of this report. These codes or standards often provide supplemental information as guidance.

3.2 Formwork:

Conform formwork components are available for four different wall designs: CF4, CF6, CF8 and CF8i. CF4, CF6 and CF8 components form walls that are nominally 4, 6, and 8 inches (100, 150, and 200 mm) thick, respectively. The resulting concrete walls are 3.74, 5.71 and 7.67 inches (95, 145 and 195 mm) thick, respectively. CF8i components include 2.22 inches (57 mm) of rigid spray-applied polyurethane insulation and form walls that are nominally 8 inches (200 mm) thick. The resulting concrete walls are 5.47 inches (139 mm) thick. [Table 1](#) shows dimensions and physical properties of the unfilled Conform components to allow design of the formwork, and of the resulting concrete walls.

Conform formwork components are available in two different configurations: Configuration 1 (for CF4, CF6, CF8 and CF8i) and Configuration 2 (for CF6, CF8 and CF8i), as described in this section.

Configuration 1: Each Conform formwork is primarily comprised of single-cell box connector components and triple-cell panel components. The single-cell box connectors interlock with the triple-cell panels to form a monolithic wall formwork. Both the box connector and panel components must be used to construct the Conform system. See Figures 1 and 2 for details of the interlocking box connector and panel components.

Configuration 2: The primary components are U250 Universal triple-cell panels, which have a male interlocking leg on one end and a female receiving slot on the other end. The male interlocking leg of one U250 Universal panel engages with the female receiving slot of the adjacent U250 Universal panel to form a monolithic wall formwork. See Figure 3 for illustrations of U250 Universal panels.

For both configurations, the components are manufactured in lengths (i.e., wall height) up to 21 feet (6500 mm). Accessory components include corner units, spacers and units for creating intersecting walls. Components may be preassembled by the manufacturer into sections up to 7 feet 4 inches (2233 mm) wide (i.e., wall length).

3.3 Materials:

3.3.1 Conform Formwork: Conform components are manufactured by a co-extrusion process, from a rigid polymer-based composite material that is identified by the manufacturer as Royalloy™ B. Royalloy™ B is a proprietary blend of polyvinyl chloride resin, acrylic modifiers, waxes, lubricants, tin stabilizers, ultraviolet protectants, smoke suppressant and flame retardant. The specified ultimate tensile strength of Royalloy™ B is 6,000 psi (41.8 MPa) and the modulus of elasticity is 0.54×10^6 psi (3730 MPa). Royalloy™ B is a Class CC1 plastic in accordance with IBC Section 2606.4. Royalloy™ B has a flame-spread index of 25 or less and a smoke-developed index of 450 or less, when filled with concrete and tested in accordance with ASTM E84. The maximum thickness of the Royalloy™ B material is 0.10 inch (2.54 mm).

3.3.2 Foam Plastic Insulation: The factory-applied insulation used in the CF8i forms is a spray-applied polyurethane foam, provided by suppliers as noted in the manufacturer's quality control manual. The foam plastic has a flame-spread index of not more than 25 and a smoke-developed index of not more than 450, at a nominal density of 2.0 pcf (9.764 kg/m³) and a maximum thickness of 4 inches (102 mm), when tested in accordance with ASTM E84.

3.3.3 Concrete: Conform formwork must be filled with normalweight concrete having a maximum aggregate size of $\frac{3}{8}$ inch (9.5 mm), a minimum slump of $4\frac{1}{2}$ inches (114 mm), a minimum 28-day compressive strength of 3,000 psi (20.5 Mpa), and must comply with Chapter 19 of the IBC or Section R608.5.1 of the IRC.

3.3.4 Steel Reinforcement: Deformed steel reinforcement bars must have a minimum yield stress of 40 ksi (275 MPa) and must comply with the applicable code.

3.4 Properties of Concrete-filled Forms:

Walls comprised of concrete-filled CF4, CF6 and CF8 forms are noncombustible in accordance with IBC Section 703.5.2. The walls have a Class A interior finish rating when tested in accordance with ASTM E84 and may be left exposed to the interior of the building.

Walls formed using Conform components may be left exposed to the exterior or may be covered with an approved exterior wall covering. Installation of a water-resistive barrier over the formwork is optional, based on testing in accordance with IBC Section 1403.2, exception 2. Installation of a vapor retarder is also optional.

The evaluation of termite-resistance of foam plastic is outside the scope of this report, and CF8i formwork must be restricted under Section 2603.8 of the IBC or Section R318.4 of the IRC.

For below-grade installations, the Conform formwork provides dampproofing for the concrete in accordance with Section 1805 of the IBC and Section R406 of the IRC. An additional vapor barrier or dampproofing is optional.

4.0 DESIGN AND INSTALLATION

4.1 General:

Design and installation of Conform formwork, reinforcing steel and concrete must comply with this report and the manufacturer's published installation instructions. The manufacturer's published installation instructions must be available at the jobsite at all times during installation.

4.2 Design:

4.2.1 Conform Formwork: Conform formwork must be braced in accordance with the applicable code to resist wind, seismic and construction loads, including hydrostatic pressures from the placement of concrete, until the permanent supporting roof and floor diaphragms are installed.

4.2.2 Concrete Walls: Design must comply with Sections 4.2.2.1 and 4.2.2.2.

4.2.2.1 Design in Accordance with the IBC: Concrete walls formed with Conform components must be designed in accordance with Chapters 16 and 19 of the IBC, using the section properties found in [Table 1](#). Foundation walls may be designed in accordance with IBC Section 1807.1.5 or prescriptive requirements in IBC Section 1807.1.6 for CF8 walls only.

4.2.2.2 Design in Accordance with the IRC: Above-grade concrete walls formed with Conform components must be designed in accordance with the provisions of ACI 318. Alternatively, if all the applicability provisions of IRC Section R608.2 are met, the walls may be designed as flat insulating concrete form (ICF) walls in accordance with IRC Section R608, including the requirements for wall openings and lintels. Foundation walls formed with Conform components must be designed in accordance with the provisions of ACI 318 or in accordance with IRC Section R404.1.3, as applicable. See [Table 2A](#) for a list of applicable prescriptive design tables.

4.2.2.3 Lintels:

4.2.2.3.1 IBC: The concrete wall above the opening must be designed as a concrete beam in accordance with the code; or a lintel comprised of back-to-back steel angles, specified in the structural design, must be cast into the concrete.

4.2.2.3.2 IRC: The lintels may be designed in accordance with the IBC or, if all the applicability provisions of IRC Section R608.2 are met, the lintels may be designed in accordance with IRC Section R608.8.

4.2.3 Connections: Connections to the wall assembly, including attachment of interior and exterior wall coverings, must be into the concrete core, and must be approved by the code official. For walls designed in accordance with the IRC, the connections must comply with IRC Section R608.9.

4.2.4 Fire-resistance Rating: Concrete walls constructed with the CF6, CF8 and CF8i components have a two-hour fire-resistance rating as limited load-bearing walls. The applied factored load (P_u) is limited to the lesser of the following:

a. 42.5 kips/ft (619.6 kN/m)

b. 46% of the design strength (ϕP_n) determined in accordance with Section 11.5 or Section 14.5 of ACI 318-14, as applicable.

4.2.5 Exterior Walls of Type I, II, III, and IV Construction: Concrete walls constructed with the CF8i forms comply with the requirements of IBC Section 2603.5 and may be used as exterior walls in buildings of Type I, II, III or IV construction of any height. Walls comprised of concrete-filled CF4, CF6 and CF8 forms are noncombustible in accordance with IBC Section 703.5.2 and may therefore also be used as exterior walls of buildings of Type I, II, III or IV construction of any height.

4.2.6 Fire Separation Distance: The Conform formwork may be used for exterior walls with a fire separation distance of 5 feet (1525 mm) or less, in accordance with IBC Section 1406.2. Required fire

separation based on fire-resistance rating must be determined in accordance with IBC Table 602. For buildings constructed in accordance with the IRC, walls formed with the CF4 components are not permitted to be used as exterior walls with a fire separation distance of less than 5 feet (1525 mm), in accordance with IRC Section R302.1.

4.3 Installation:

4.3.1 Formwork: Conform formwork must be installed on footings and foundations complying with Chapter 18 of the IBC or Chapter 4 of the IRC. Reinforcing dowels connecting the walls to the footing are to be cast in place or post installed prior to the erection of the Conform formwork and must extend into the base of the wall system for the minimum developed length necessary for compliance with Chapter 25 of ACI 318. Each piece of Conform formwork may be installed independently, or several pieces may be installed in preassembled sections. Formwork is to be installed with the label end up to ensure that the holes in the component webs align. For walls that are over 21 feet (6500 mm) high, the Conform components are split into two or more lengths. The joints in the box and panel components are staggered near the mid-height of the wall.

4.3.2 Steel Reinforcing Bars: Vertical bars are installed in the box connectors and the cells of the panels for Configuration 1 formwork, or cells of universal U250 universal panels for Configuration 2 formwork, as required by the structural design. Vertical bars must be installed prior to horizontal bars, except at corners. If specified, the vertical bars are tied to the dowels, either by lifting the installed formwork, or by installing the formwork after the vertical bars are installed. To ensure proper placement in the wall, wire hoops that match the diagonal dimension of the open cells are tied to the vertical bars. Horizontal bars are installed through the holes in the webs of the Conform components. When horizontal reinforcing is required to continue around corners, bars with 180-degree standard hooks, complying with ACI 318, are installed in both directions and lapped with the straight bars as specified. A vertical bar is then installed through the two overlapping hooked bars. For plain concrete and reinforced concrete walls designed in accordance with Chapter 19 of the IBC, not less than two No. 5 (16 mm) bars must be provided around all door and window openings. Such bars must be extended beyond the corners of the openings not less than 24 inches (610 mm). For walls designed in accordance with the IRC, the steel reinforcing must comply with Section R608.5.2 of the IRC.

4.3.3 Concrete: Concrete is to be placed in the forms in accordance with the applicable code and the manufacturer's installation instructions. The concrete must be allowed to cure in accordance with Section 26.5.3 of ACI 318, before the installation of floor and roof framing.

4.3.4 Thermal Barrier: Where the insulated side of the CF8i formwork is facing the interior of the building, the formwork must be separated from the interior of the building by a thermal barrier of $\frac{1}{2}$ -inch (12.7 mm) gypsum board fastened to light-gage steel framing installed in front of the wall. The construction of the light gage steel framed wall must comply with IBC Section 2210, and the gypsum board must conform to ASTM C1396 and be installed in accordance with IBC Section 2508.

4.4 Special Inspection:

Special inspections in accordance with IBC Section 1705.3 are required; except for CF8 walls constructed using the prescriptive requirements of IBC Section 1807.1.6. In jurisdictions adopting the IRC, walls constructed in accordance with ACI 318 are subject to the special inspections required by IBC Section 1705.3. Under the IRC, walls constructed in accordance with Section 4.2.2.2 are not subject to special inspections.

5.0 CONDITIONS OF USE:

The Conform formwork described in this report complies with, or is a suitable alternative to what is specified in, those codes listed in Section 1.0 of this report, subject to the following conditions:

- 5.1 Installation complies with this report, the manufacturer's published installation instructions and the applicable code. If there is a conflict between the manufacturer's published installation instructions and this report, this report governs.
- 5.2 Structural calculations and plans, showing compliance with this report and the code, must be submitted to the code official for approval. The calculations and plans must be prepared by a registered design professional when required by the statutes of the jurisdiction in which the project is to be constructed.
- 5.3 Walls must be supported by footings and foundations complying with Chapter 18 of the IBC or Chapter 4 of the IRC.
- 5.4 Walls constructed using Conform formwork are not permitted to be installed where the surface temperature of the wall is expected to exceed 185°F (85°C).

- 5.5 Special inspections must be performed in accordance with Section 4.4 of this report.
- 5.6 When required by Section 4.3.4 of this report, a thermal barrier must be installed.
- 5.7 Bearing walls constructed using Conform formwork are limited to use in the construction types defined in IBC Table 601, based upon the fire-resistance ratings given in Section 4.2.4 of this report.
- 5.8 Walls must satisfy requirements described in Section 3.4 of this report.
- 5.9 Conform CF8i formwork is produced in Woodbridge, Ontario, Canada, under a quality control program with inspections by ICC-ES.

6.0 EVIDENCE SUBMITTED

- 6.1 Report of testing of tensile properties in accordance with ASTM D638.
- 6.2 Report of testing of weatherability in accordance with ASTM D1925, D2244 and D4226.
- 6.3 Report of testing of flash ignition and self-ignition in accordance with ASTM D1929.
- 6.4 Report of fire-resistance testing in accordance with ASTM E119 and related engineering analysis.
- 6.5 Report of testing of surface-burning characteristics in accordance with ASTM E84.
- 6.6 Report of air leakage testing in accordance with ASTM E283.
- 6.7 Report of water penetration testing in accordance with ASTM E331 and ASTM E547.
- 6.8 Report of ignitability testing in accordance with NFPA 268.
- 6.9 Report of potential heat testing in accordance with NFPA 259.
- 6.10 Report of rate of burning testing in accordance with ASTM D635.
- 6.11 Report of flammability testing in accordance with NFPA 285.
- 6.12 Report of heat and visible smoke release rate testing in accordance with ASTM E1354.
- 6.13 Quality documentation in accordance with the [ICC-ES Acceptance Criteria for Quality Documentation \(AC10\)](#), dated June 2014.

7.0 IDENTIFICATION

- 7.1 Each component of the Conform formwork is identified with a label indicating the manufacturer's name (Nuform Building Technologies Inc.) and address, the product name (Conform), the part number of the component, and the evaluation report number (ESR-1223). The CF8i components must also bear the flame-spread and smoke-developed indices of the foam insulation.
- 7.2 The report holder's contact information is the following:
NUFORM BUILDING TECHNOLOGIES INC.
100 GALCAT DRIVE, UNIT #2
WOODBRIIDGE, ONTARIO L4L 0B9
CANADA
(905) 652-0001
www.nuformdirect.com

8.0 OTHER CODES

8.1 Evaluation Scope:

In addition to the codes referenced in Section 1.0, the products described in this report were evaluated for compliance with the 2012 *International Building Code*[®] (IBC) and the 2012 *International Residential Code*[®] (IRC). The products comply with these codes as noted below.

8.2 Uses:

See Section 2.0.

8.3 Description:

- 8.3.1 **General:** See Section 3.1.
- 8.3.2 **Formwork:** See Section 3.2.

8.3.3 Material:

8.3.3.1 Conform Formwork: See Section 3.3.1.

8.3.3.2 Foam Plastic Insulation: See Section 3.3.2.

8.3.3.3 Concrete: See Section 3.3.3 except reference to 2015 IRC Section R608.5.1 is revised to reference to 2012 IRC Section R611.5.1.

8.3.3.4 Steel Reinforcement: See Section 3.3.4.

8.3.4 Properties of Concrete-filled Forms: See Section 3.4, with the following modifications:

The evaluation of termite resistance of foam plastic is outside the scope of this report, and CF8i formwork must be restricted under Section 2603.9 of the 2012 IBC or Section R318.4 of the 2012 IRC.

8.4 Design and Installation:

8.4.1 General: See Section 4.1.

8.4.2 Design:

8.4.2.1 Conform Formwork: See Section 4.2.1.

8.4.2.2 Concrete Walls: Design must comply with Sections 8.4.2.2.1 and 8.4.2.2.2.

8.4.2.3 Design in Accordance with the IBC: See Section 4.2.2.1.

8.4.2.4 Design in Accordance with the IRC: See Section 4.2.2.2 except references to 2015 IRC Sections R608.2 and R404.1.3 are revised to reference the 2012 IRC Sections R611.2 and R404.1.2, respectively. See [Table 2B](#) for a list of applicable prescriptive design tables.

8.4.2.5 Lintels:

8.4.2.6 IBC: See Section 4.2.2.3.1.

8.4.2.7 IRC: The lintels may be designed in accordance with the IBC or, if all the applicability provisions of IRC Section R611.2 are met, the lintels may be designed in accordance with IRC Section R611.8.

8.4.2.8 Connections: See Section 4.2.3 except reference to 2015 IRC Section R608.9 is revised to reference 2012 IRC Section R611.9.

8.4.2.9 Fire-resistance Rating: See Section 4.2.4 except references to the ACI 318-14 Sections 11.5 and 14.5 are revised to references to ACI 318-11 Sections 14.5 and 22.6, respectively.

8.4.2.10 Exterior Walls of Type I, II, III and IV Construction: See Section 4.2.5.

8.4.2.11 Fire Separation Distance: See Section 4.2.6.

8.4.3 Installation:

8.4.4 Formwork: See Section 4.3.1 except reference to ACI 318-14 Chapter 25 is revised to ACI 318-11 Chapter 12.

8.4.5 Steel Reinforcing Bars: See Section 4.3.2 except reference to 2015 IRC Section R608.5.2 is revised to reference 2012 IRC Section R611.5.2.

8.4.6 Concrete: See Section 4.3.3 except reference to ACI 318-14 Section 26.5.3 is revised to reference ACI 318-11 Section 5.11.

8.4.7 Thermal Barrier: See Section 4.3.4.

8.4.8 Special Inspection: See Section 4.4 except reference to Section 4.2.2.2 is revised to reference to Section 8.4.2.2.2.

8.5 Conditions of Use:

See Section 5.0, except the following modifications:

Section 5.5: Special inspections must be performed in accordance with Section 8.4.4 of this report.

Section 5.6: When required by Section 8.4.3.4 of this report, a thermal barrier must be installed.

Section 5.8: Walls must satisfy requirements described in Section 8.3.4 of this report.

8.6 Evidence Submitted:

See Section 6.0.

8.7 Identification:

See Section 7.0.

TABLE 1—SECTION PROPERTIES (PER FOOT OF WIDTH)

FORM	ELEMENT	MASS (lbf/ft. ²)	A (inch ²)	I _x (inch ⁴)	S _x (inch ³)	r (inch)	t (inch)
CF4	Polymer ¹	2.5	3.32	11.39	5.79	1.85	3.94
	Concrete	45.1	42.67	49.66	26.58	1.08	3.74
CF6	Polymer ¹	2.7	3.45	27.34	9.26	2.82	5.91
	Concrete	69.4	65.43	177.50	62.22	1.65	5.71
CF8	Polymer ¹	2.9	3.59	51.11	12.98	3.77	7.87
	Concrete	93.6	88.20	433.34	88.20	2.22	7.67
CF8i	Polymer ¹	4.4	5.02	53.67	11.68 ²	3.27	7.87
	Concrete	66.8	63.11	157.29	57.52	1.58	5.47

For SI: 1 inch = 25.4 mm, 1 inch² = 645.16 mm², 1 inch³ = 16 387 mm³, 1 inch⁴ = 41.62 × 10⁴ mm⁴, 1 lbf/foot² = 4.88 kg/m².

¹Values are based on Conform flange thickness of 0.100 inch and a web thickness of 0.072 inch.

²Minimum value at nonfoamed face.

TABLE 2A—APPLICABLE PRESCRIPTIVE TABLES UNDER THE 2015 IRC

FORM	CONCRETE THICKNESS (inches)	ABOVE GRADE IRC ¹	FOUNDATION IRC
CF4	3.74	Table R608.6(1) column headed 4 inch	Not allowed
CF6	5.71	Table R608.6(1) column headed 6 inch	Table R404.1.2(2) ²
CF8	7.67	Table R608.6(1) column headed 8 inch	Table R404.1.2(3) ²
CF8i	5.47	Table R608.6(1) column headed 6 inch	Table R404.1.2(2) ²

TABLE 2B—APPLICABLE PRESCRIPTIVE TABLES UNDER THE 2012 IRC

FORM	CONCRETE THICKNESS (inches)	ABOVE GRADE IRC ¹	FOUNDATION IRC
CF4	3.74	Table R611.6(1) column headed 4 inch	Not allowed
CF6	5.71	Table R611.6(1) column headed 6 inch	Table R404.1.2(2) ²
CF8	7.67	Table R611.6(1) column headed 8 inch	Table R404.1.2(3) ²
CF8i	5.47	Table R611.6(1) column headed 6 inch	Table R404.1.2(2) ²

For SI: 1 inch = 25.4 mm.

¹For buildings constructed in accordance with the applicability limits of 2015 IRC Section R608.2 (2012 IRC Section R611.2, as applicable).

²For buildings constructed in accordance with the applicability limits of 2015 IRC Section R404.1.3 (2012 IRC Section R404.1.2, as applicable).

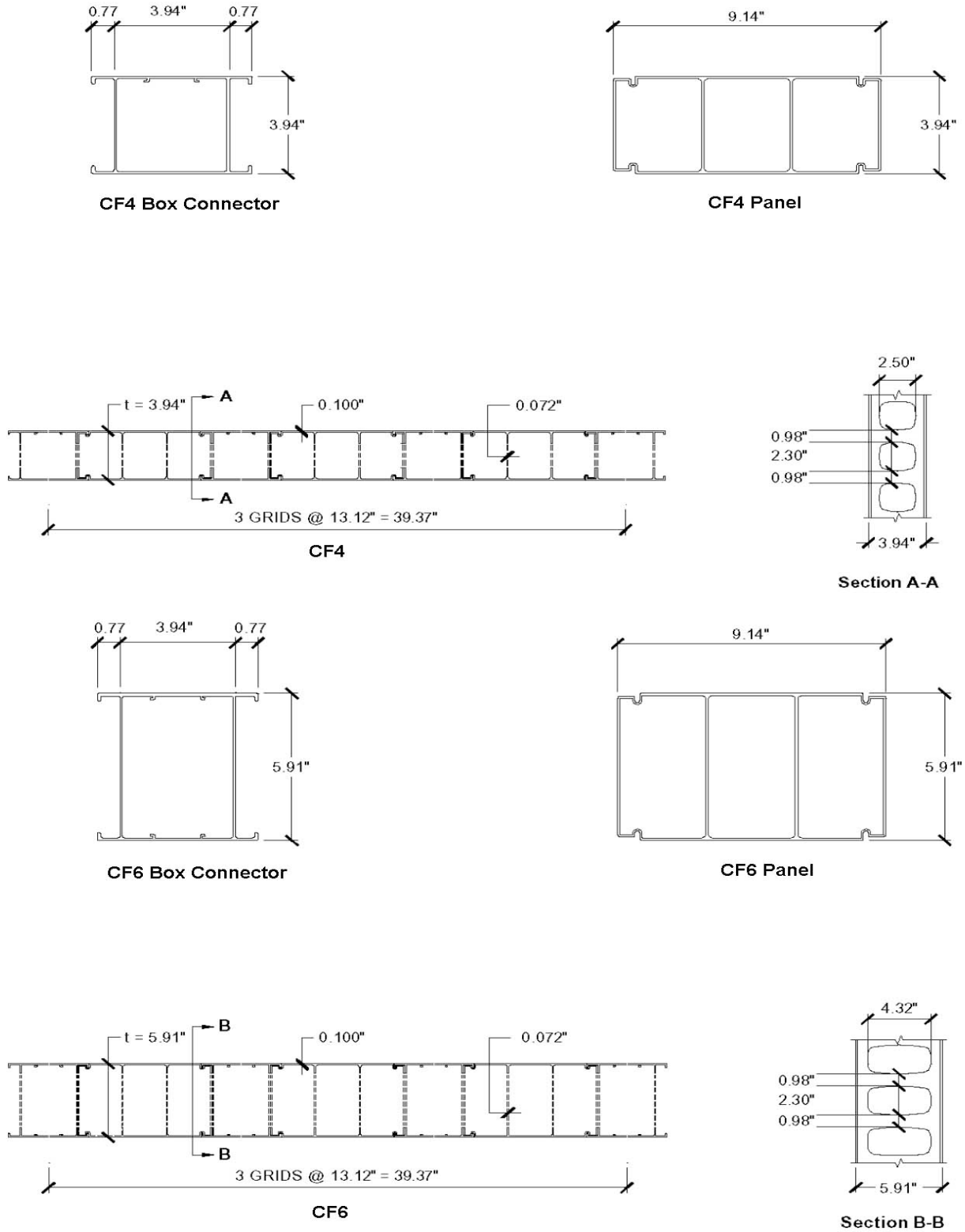

For SI: 1 inch = 25.4 mm.

FIGURE 1—CF4 AND CF6 BOX CONNECTORS AND PANELS

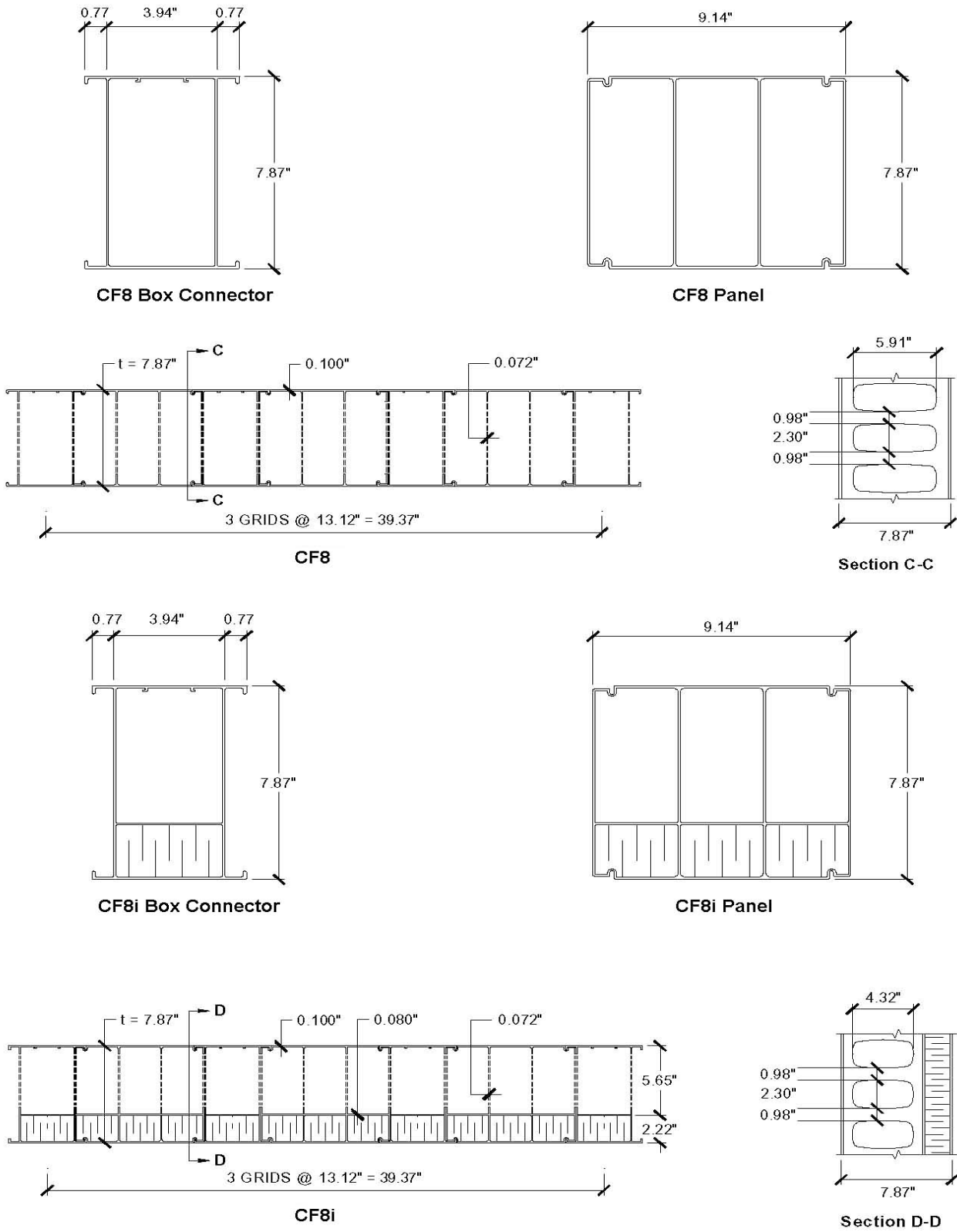

For SI: 1 inch = 25.4 mm.

FIGURE 2—CF8 AND CF8i BOX CONNECTORS AND PANELS

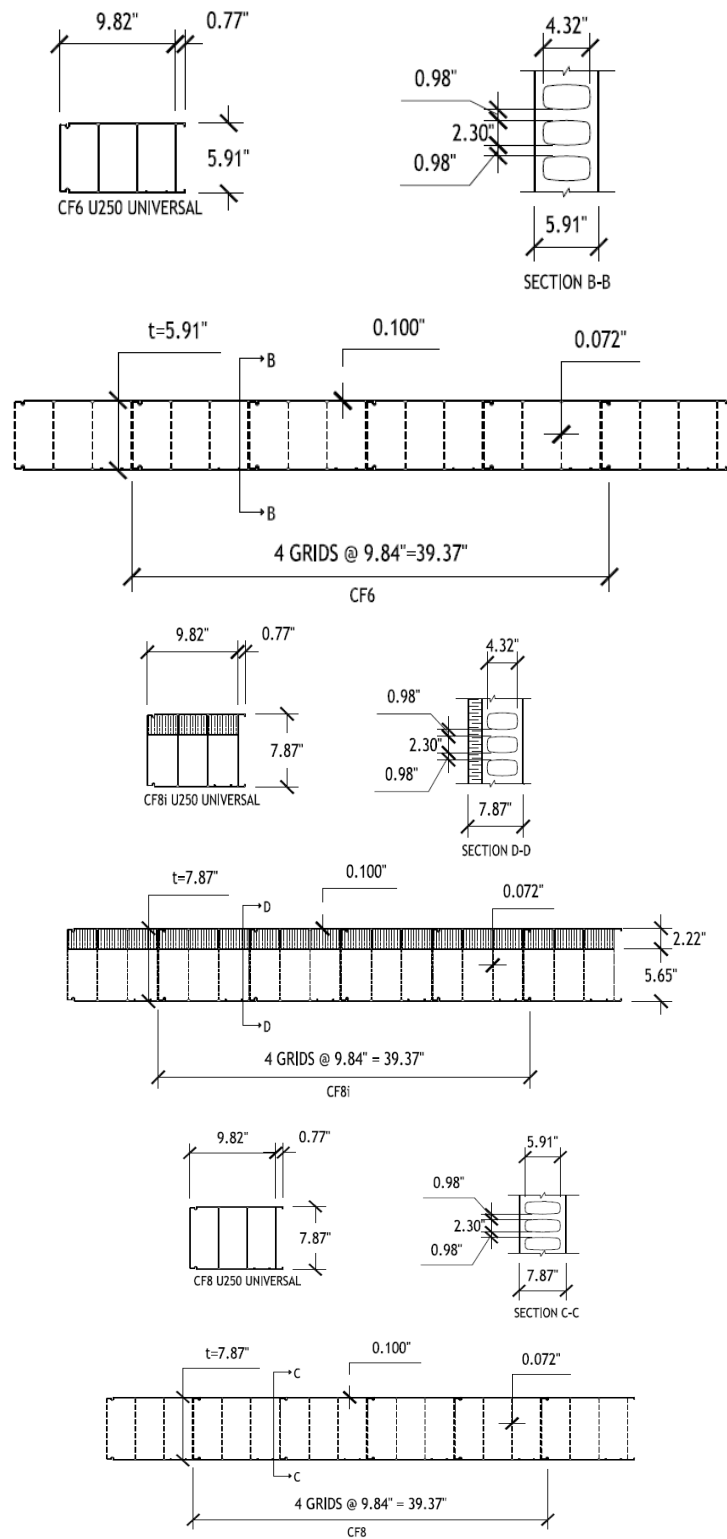

FIGURE 3—CF6, CF8 AND CF8i U250 UNIVERSAL PANELS

DIVISION: 03 00 00—CONCRETE
Section: 03 11 00—Concrete Forming

REPORT HOLDER:

NUFORM BUILDING TECHNOLOGIES INC.

EVALUATION SUBJECT:

CONFORM®

1.0 REPORT PURPOSE AND SCOPE**Purpose:**

The purpose of this evaluation report supplement is to indicate that the Conform® formwork system, described in ICC-ES evaluation report ESR-1223, has also been evaluated for compliance with the codes noted below.

Applicable code editions:

- 2014 *Florida Building Code—Building*
- 2014 *Florida Building Code—Residential*

2.0 CONCLUSIONS

The Conform® formwork system, described in Sections 2.0 through 7.0 of the master evaluation report ESR-1223, complies with the *Florida Building Code—Building* and the *Florida Building Code—Residential*, provided the design and installation are in accordance with the 2012 *International Building Code*® (IBC) provisions noted in the evaluation report.

Use of the Conform® formwork system for compliance with the High-Velocity Hurricane Zone provisions of the *Florida Building Code—Building* and *Florida Building Code—Residential* has not been evaluated, and is outside the scope of this supplemental report.

For products falling under Florida Rule 9N-3, verification that the report holder's quality assurance program is audited by a quality assurance entity approved by the Florida Building Commission for the type of inspections being conducted is the responsibility of an approved validation entity (or the code official when the report holder does not possess an approval by the Commission).

This supplement expires concurrently with the evaluation report, reissued October 2023.